

ADDENDUM
ADA'S ALLEY

MASSING COMBINATIONS

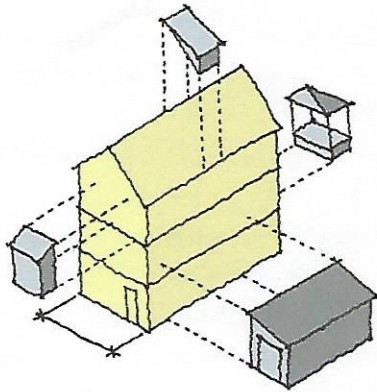

3 story gable with front porch, single garage wing, dormer and balcony additions

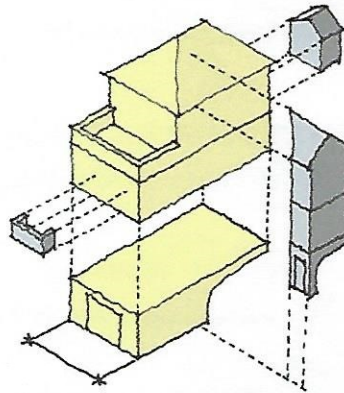

2 story hip with front entry, single garage, stair tower and balcony

LOT PLACEMENT

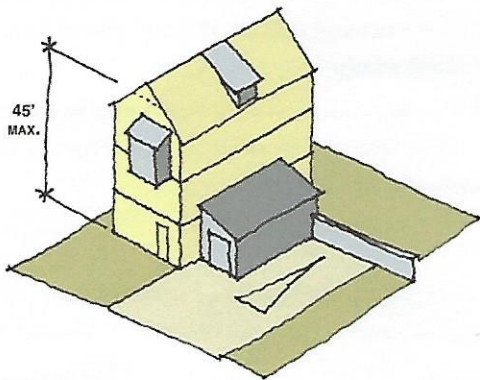

Lots may have a mix of parking conditions; entries from Ada's Alley are required (at-grade encouraged)

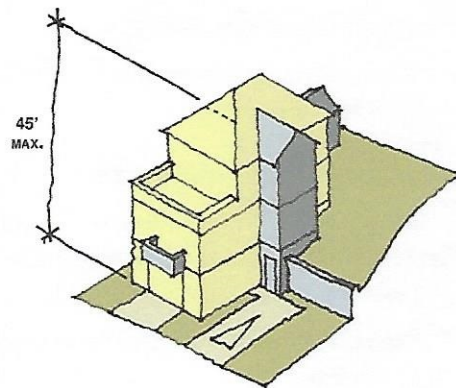

Towers are a recommended point of entry and location for interior stairs

ADA'S ALLEY

The Ada's Alley address offers a prime location on Roche Harbor Road while providing a less formal entry on the alley side. These lots feature a tall downhill facade atop a garage and have a low, cottage-scaled composition from the uphill side. Ada's Alley lots enjoy close proximity to The Marina and views toward the harbor below.



LOT SIZE

- » Lot Dimensions: Approximately 80 to 100 feet wide by 37 to 53 feet deep
- » Lot Area: 3,600 to 4,800 square feet

MINIMUM SETBACKS

- » Front Yard: 8 feet from property line
- » Side Yard: 6 feet from side property line
- » Rear Yard: 3 feet from rear property line

DEVELOPMENT ZONES

- » Facade Zone: 10 feet at rear yard; 5 feet at front yard
- » Minimum 60% of main body street facades must be in Facade Zone

ENCROACHMENTS AND SETBACKS

- » Wings, porches and balconies: 3 feet into Front Yard
- » Eaves, balconies and other overhangs: 3 feet into Rear Setback so far as they are a minimum 10 feet above finished grade.

MAIN BODY

- » Massing form must be Gable or Tower House
- » Narrow facades of the main body must face Roche Harbor Road and Ada's Alley.
- » May have detached Garage or Sleeping Quarters (1-Story).
- » Guest House (Max 16 feet x 24 feet)

WINGS, PORCHES AND BALCONIES

- » Entry porches: minimum 8 feet deep and must be 18 to 30 inches off finished grade where stairs are located. Garage-level entry is permitted to be at grade.
- » May share eave lines with but not ridge heights with the main body massing
- » Minimum of one wing porch or balcony is required on front and rear elevations.
- » Maximum conditioned wing floor area on one lot must be 20% or less of the aggregate floor area.

GARAGES AND PARKING

- » Exact location of Garage Zone or Parking Court Zone within the lot will be determined by the unit layout
- » Minimum 2-off street parking spaces required.
- » Detached garages may be 1-story massing; main massing of garage may not exceed 16 feet in width and 24 feet length.
- » Parking pads and other covered parking must be to either side of the garage and is not permitted between the garage and Ada's Alley.
- » Garages must orient toward Ada's Alley or parking court.
- » Garage doors larger than one stall wide are not permitted; No more than two in a row is permitted

TOWERS AND STAIRS

- » Towers are permitted when engaged into main body massing of the house.
- » Towers are not to exceed 1½ stories above uppermost main body story and may not be larger than 12 feet in either depth or width.
- » Site stairs and porch stairs are not permitted to encroach into public right-of-way and must not be greater than ten sequential treads.
- » Bridge or fill for pedestrain walk connection to right-of-way.

SITE WALLS

- » Site walls are not permitted to encroach into public right-of-way and must not be greater than five feet tall.
- » Terracing is allowed at a minimum of 3 feet horizontal distance when a site wall taller than 5 feet is desired.